



<https://doi.org/10.15407/scine16.02.051>

**MYKOLA SURIANINOV¹, YURIY OTROSH²,
PAVLO BALDUK¹, and ILGAR FIRDOVS DADASHOV³**

¹Odesa State Academy of Civil Engineering and Architecture,
Didrickson St., 4, Odesa, 65029, Ukraine,
+380 50 333 3754, sng@ogasa.org.ua

²National University of Civil Defence of Ukraine,
Chernishevska St., 94, Kharkiv, 61023, Ukraine,
+380 63 794 5621, yuriyotrosh@gmail.com

³Academy of the Ministry of Emergency Situations of Azerbaijanian Republic,
Elman Gasimov St., 8, Baku, Hovsan settlement, AZ1089, Azerbaijan,
+994 50 516 7695, lgardadashov.69@gmail.com

EXPERIMENTAL AND COMPUTER RESEARCH OF REINFORCED CONCRETE COLUMNS UNDER HIGH TEMPERATURE EFFECTS

Introduction. *The unsatisfactory technical condition of many buildings and structures is the result of their aging and requires a quick evaluation of the technical condition.*

Problem Statement. *It is necessary to conduct an experimental research, since it is analytically difficult to describe the stress-strain state of structures. The most promising way for verifying these experimental research data is computer simulation of structures, including in the condition of a fire. It is advisable to use the ANSYS software.*

Purpose. *To carry out experimental studies of the stress-strain state of a reinforced concrete column at a high temperature and to make a computer simulation of the process with subsequent comparison of the results.*

Materials and Methods. *Experimental fire tests of reinforced concrete columns have been conducted in order to determine the time interval between the start of the test and the establishment of normalized limit of fire resistance for the column based on the loss of supporting capability in the normal temperature conditions. In order to evaluate the quality of the experiment and the reliability of the obtained temperature distribution, a computer simulation of the two columns using the ANSYS R.17.1 software has been made.*

Results. *A comparative analysis of the results of experimental studies and a numerical analysis have been done. The temperature field distribution in the column is ambiguous and depends on the location of control points.*

Conclusions. *The obtained results have confirmed that the experimental research and computer simulation with further numerical analysis can be recommended for practical use. The mathematical model makes it possible to operatively predict the controlled parameters of building structures. Conclusions on the operability of building structures with the possible tendency to deterioration of their technical condition under force impact and high temperature effects taken into consideration are advisory rather than mandatory.*

Key words: ANSYS, fire, computer simulation, concrete columns, and building structures.

Citation: Mykola Surianinov, Yuriy Otrosh, Pavlo Balduk, and Ilgar Firdovs Dadashov. Experimental and Computer Research of Reinforced Concrete Columns Under High Temperature Effects. *Sci. innov.* 2020. V. 16, no. 2. P. 51–56. <https://doi.org/10.15407/scine16.02.051>

ISSN 2409-9066. *Sci. innov.* 2020. 16(2)

The poor technical condition of many buildings and structures is a consequence of their aging and requires an urgent assessment of the technical condition to prevent emergencies [1–2]. The degree of fire-caused damage to reinforced concrete structures is very difficult to determine. The heterogeneity of the physical and mechanical properties of reinforced concrete materials at a high temperature leads to their different temperature deformations, with bonds between individual components broken [3–4]. The multifaceted nature of the changes makes it virtually impossible to analytically describe the stress-strain state of structures [5], therefore it is necessary to fall back upon results of experimental studies. However, these results usually have a wide spread and depend on many factors. So, the experiment data need to be verified. In our view, the most promising way for this is computer-aided fire design that can be implemented with many modern finite element programs, one of which is the ANSYS package [6, 7].

The purpose of this research is to experimentally study the stress-strain state of a reinforced concrete column at a high temperature, to make a computer-aided simulation of the process, and then to compare the results at control points.

Columns, as vertically oriented bar-shaped supporting structures, are exposed to fire from four or three sides. The fire resistance tests of these structures are governed by the national standard DSTU B B.1.1-13: 2007 Fire Protection. Columns. Test Method for Fire Resistance (EN 1365-3: 1999, NEQ) [8]. The standard is intended to determine the limit of fire resistance of columns made of reinforced concrete, timber, and the like, as well as steel columns with flame-retardant coating or membrane fireproofing.

The essence of the test method is to determine the time interval from the start of exposure to the starting point of the limit fire resistance state for the column based on the loss of supporting capability (R) in normal temperature conditions according to DSTU B B.1.1-4-98* [9].

The standard temperature conditions are characterized by a standard curve of temperature change depending on duration of fire resistance test [10, 11]:

$$t = 345 \lg(8\tau + 1) + t_e, \quad (1)$$

where t is environment temperature; τ is time, min; t_e is initial temperature.

The limiting condition, in terms of the supporting capability loss, for load-tested columns and for load-free tested reinforced concrete columns is the sample collapse or reach of the temperature limits for steel columns coated with flame-retardant.

In the case of testing load-free reinforced concrete column samples, it is necessary to install, at least, 10 thermocouples at equal intervals over the thickness, in the center of the sample, to determine the fire resistance limit.

For testing load-free reinforced concrete column samples, the time of reach of the limit state in terms of the supporting capability loss is determined based on temperature measurements over the sample's thickness, by the calculation method that should meet the requirements of the DBN B.1.1-7-2016 [12].

The limit fire resistance and the class of fire resistance of the column are determined in accordance with DSTU B V.1.1-4-98 * [8].

For the purpose of tests, two identical (sample No. 1 and sample No. 2) steel-cased reinforced concrete columns having a height of 2000 mm and a cross section of 600×600 mm were manufactured at the Brovary Plant of Reinforced Concrete Products. Each sample had a support frame that consisted of eight 20 mm diameter vertical reinforcement wires of A400C class according to DSTU 3760:2006 [13]. The horizontal reinforcement is made of 10 mm diameter wires of class A240C and is mounted along the outer contour of the vertical reinforcement wires. In addition, 10 mm diameter wires of A240C class, which connected the central rods on each face were used (Fig. 1).



Fig. 1. General view of reinforcement frame of column sample

In addition, additional samples (cubes, prisms, fragments of reinforcing wires) were made, and their tests enabled obtaining data on the physical and mechanical properties of the materials used.

All samples were made of concrete of the same composition. Consumption of materials per 1 m³ of the mix was as follows: 440 kg cement, 660 kg sand, 1150 kg crushed stone, 153 l water, 17 kg chemical additives (Relaxol-Leader). The water-cement ratio was 0.35, the cone slump was 14–15 cm. The class of concrete was B25.

Having been eased, the columns and the additional samples were kept for 28 days.

In order to establish the uniformity and properties of the used concrete, having been manufactured the columns were instrumentally studied by non-destructive methods. The strength of concrete cubes, prisms, and columns was measured by the ultrasonic method according to DSTU B V.2.7-226: 2009 [14].

The number and location of control points in the columns were determined in accordance with the requirements of DSTU B V.2.7-214: 2009 [15].

First, the column measurements were made prior to fire tests, using an ultrasonic device UK-14PM with an absolute error of ultrasound propagation time $\pm 0,01t + 0,1$ ms. The measurements were made by the method of end-to-end exposure to sound using mechanically unbound piezoelectric converters with a resonant frequency of 60 kHz.

To determine the strength of concrete in the control points, we used the basic calibration dependence "speed-strength" made for the used de-

vice based on long-term statistics of the results of comparative ultrasonic and mechanical tests of concrete (classes C12 / 15, ..., C28 / 35) and the data of cube and prism tests. According to the results of the studies, it was found that the concrete used for the manufacture of columns, in strength, corresponds to the class C20 / 25.

After the preliminary tests, the next step was testing the columns under fire. Since the columns were tested without load, the limit of fire resistance in terms of the supporting capability loss (R) was determined based on the temperature distribution across the column section. Supporting capability was estimated based on excess of the average temperature of the support rods by

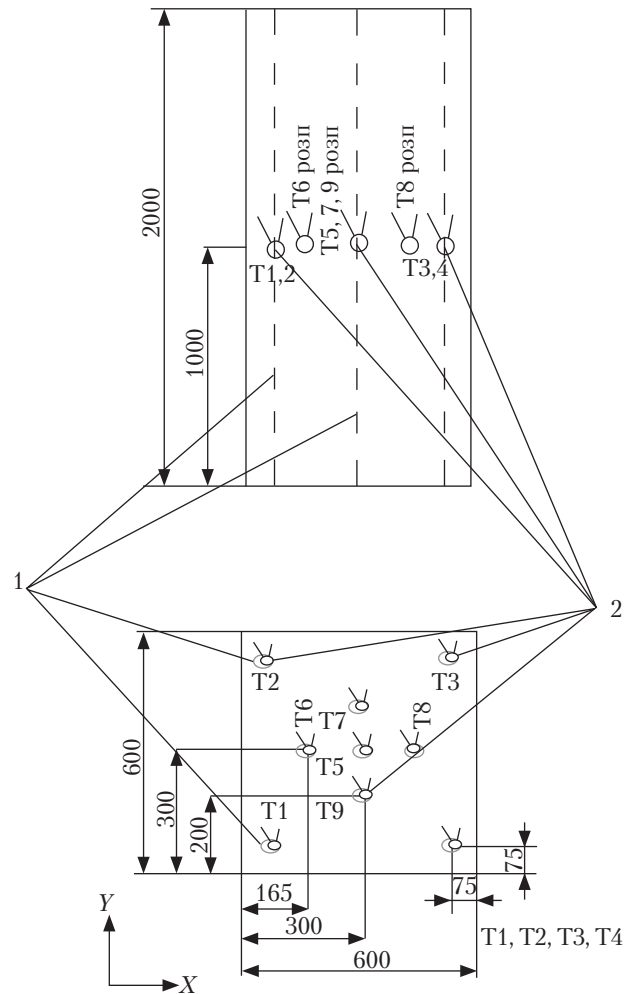

Fig. 2. Layout of thermocouples in the column

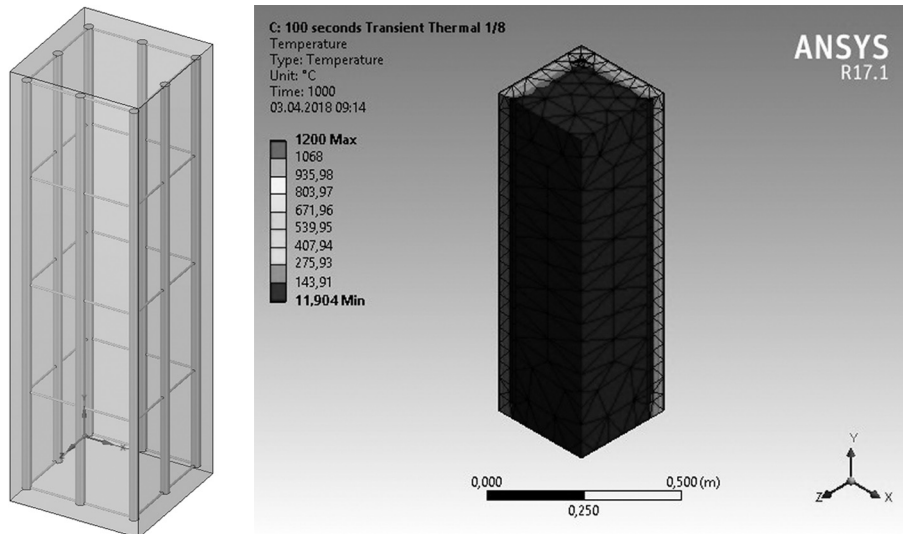

Fig. 3. Computer model of the column

480 °C, as compared with the initial temperature. To measure the temperature of the support rods of the samples, during the tests, thermocouples THA (T1... T4) were installed on four rods of each sample. Five thermocouples THA (T5... T9) were installed to obtain the temperature distribution across the sample section [16]. The layout of thermocouples is shown in Fig. 2.

As a result of the test, the limit of fire resistance was calculated by the formula

$$t_{fr} = t_{mes} - \Delta t, \quad (2)$$

where t_{fr} is fire resistance limit, min; t_{mes} is the least time from the start of the test to the reach of fire resistance limit, min; Δt is error, min.

Error Δt is estimated using the formula:

$$\Delta t = (0,015t_{mes} + 3)(A_s - A_f)/(A_s - A_{min}), \quad (3)$$

where A_s , A_f , A_{min} are integral values of standard temperature, average temperature in furnace and minimum permissible temperature in furnace, respectively.

Sample No. 1 lost its supporting capability in 152 min, since the average temperature ($T_{1, average}$) of the vertical rods exceeded the initial one by 480 °C.

After the tests, the column was inspected. There were detected numerous damages of the concrete surface in the form of cracks.

Sample No. 2 did not lose its supporting capability, as the average temperature of the support rods did not exceed the initial one by 480 °C.

Upon completion of the tests, the column was cut to determine the nature of damages and the concrete properties along the section. The cutting was made in the plant conditions, using specialized equipment. It enabled establishing the fact that in the corner zones and around the perimeter there was a destruction of concrete with circle-wise formation of cracks. A core that was almost undamaged during the tests was formed in the central part of the cross section.

The measurement results were recorded every minute. Table 1 shows the results for sample no. 1, for each 10 minutes.

In order to evaluate the quality of the experiment and the reliability of the obtained temperature distribution, a computer simulation for both columns was made using the ANSYS R17.1 software package [6] (Fig. 3a). The temperature distribution in the column at the 17th minute is given in Fig. 3b (given the symmetry, only a quarter of the column is shown).

Table. Comparison of Experiment and Computer Results

Time, min	$T_{(1-4),av}$	ANSYS	Error, %	T_5	ANSYS	Error, %	$T_{(6-9),av}$	ANSYS	Error, %
0	6	8	25.0	6	7	14.3	6	7	14.3
10	19	23	17.4	7	7	0	7	7	0
20	61	70	12.9	9	8	11.1	9	8	11.1
30	105	116	9.5	17	16	5.9	19	17	10.5
40	129	143	9.8	36	33	8.3	55	50	9.1
50	163	180	9.4	67	61	8.9	85	77	9.4
60	199	220	9.5	98	89	9.2	100	91	9.0
70	238	263	9.5	103	94	8.7	102	93	8.8
80	279	308	9.4	103	94	8.7	104	95	8.7
90	319	353	9.6	104	95	8.6	107	98	9.3
100	355	393	9.7	108	98	9.2	119	108	9.2
110	382	423	9.7	114	104	8.8	123	112	8.9
120	409	453	9.7	124	113	8.9	135	123	8.9
130	437	484	9.7	137	125	8.8	150	136	9.3
140	463	512	9.6	152	139	8.6	166	151	9.0
150	484	536	9.7	170	155	8.8	185	168	9.2
152	487	539	9.6	174	159	8.6	190	173	9.0

The analysis of Table 1 has shown that the results of experimental studies and numerical analysis with the use of ANSYS are quite different for the first 30 minutes, at all control points. However, later, this difference is stabilized and up to the end of the experiment does not exceed 10.0%, which, in our opinion, can be to consider it perfectly acceptable.

It is important that the temperature distribution across the column is not uniform and depends

on the location of the control points. In particular, the values obtained in ANSYS for the points corresponding to the location of thermocouples T1 – T4 (Fig. 2) are higher than the experiment results, while those corresponding to T5 – T9 are lower.

The results obtained confirm that the method of experimental research and computer simulation followed by numerical analysis can be recommended for practical application.

REFERENCES

1. Tiutiunyk, V. V., Ivanets, H. V., Tolkunov, I. A., Stetsyuk, E. I. (2018). System approach for readiness assessment units of civil defense to actions at emergency situations. *Naukovyi Visnyk Natsionalnoho Hirnychoho Universytetu*. 1. 99–105. doi: 10.29202/nvngu/2018-1/7.
2. Otrosh, Y., Kovalov, A., Semkiv, O., Rudeshko, I., Diven, V. (2018). Methodology remaining lifetime determination of the building structures. *MATEC Web of Conferences*. 230. 02023. <https://doi.org/10.1051/mateconf/201823002023>.
3. Korneeva, I., Neutov, S., Suriyaninov, M. (2017). Experimental studies of fiber concrete creep. *MATEC Web of Conferences*. 116. 02021. doi: 10.1051/mateconf/201711602021.
4. Kovalov, A., Otrosh, Y., Ostroverkh, O., Hrushovinchuk, O., Savchenko, O. (2018). Fire resistance evaluation of reinforced concrete floors with fire-retardant coating by calculation and experimental method. *E3S Web of Conferences*. 60. 00003. <https://doi.org/10.1051/e3sconf/20186000003>.
5. Surianinov, M., Shylyayev, O. (2018). Calculation of plate-beam systems by method of boundary elements. *International Journal of Engineering and Technology (IAE)*. 7(2). 238–241. doi: 10.14419/ijet.v7i2.23.11927.
6. Dashhenko, A. F., Lazareva, D. V., Surjaninov, N. G. (2011). *ANSYS v zadachah inzhenernoj mehaniki*. Odessa [in Russian].
7. Fedorova, N. N., Valger, S. A., Danilov, M. N., Zaharova, Ju. V. (2017). *Osnovy raboty v ANSYS 17*. Moskva [in Russian].
8. DSTU B V.1.1-14:2007 (2007). Fire protection. COLUMNS. Fire resistance test method. Kyiv [in Ukrainian].

9. DSTU B V.1.1–4–98* (2005). Fire protection Building constructions. Fire resistance test methods. General requirements. Kyiv [in Ukrainian].
10. Jakovlev. A. I. (1988). *Calculation of fire resistance of building structures*. Moskva [in Russian].
11. Pozdieiev. S. V. (2011). *Rozvytok naukovykh osnov vyznachennia mezh vohnestiikosti nesuchykh zalizobetonnykh konstruksii. Development of scientific basis for determination of limits of fire resistance of load-bearing reinforced concrete structures (Doctoral dissertation)*. Kharkiv [in Ukrainian].
12. DBN V.1.1-7:2016 (2017). Fire safety of construction. Kyiv [in Ukrainian].
13. DSTU 3760:2006 (ISO 6935-2:1991. NEQ) (2007). Rolled products for reinforcement of ferroconcrete structures. General specification. Kyiv [in Ukrainian].
14. DSTU B V.2.7-226:2009 (2010). Building materials. Concretes ultrasonic method of strenght determination. Kyiv [in Ukrainian].
15. DSTU B V.2.7-214:2009 (2010). Building materials. Concretes methods for strenght determination using reference specimens. Kyiv [in Ukrainian].
16. Andronov. V., Pospelov. B., Rybka. E. (2016). Increase of accuracy of definition of temperature by sensors of fire alarms in real conditions of fire on objects. *EasternEuropean Journal of Enterprise Technologies*. 4. 38–44. doi: 10.15587/1729-4061.2016.75063.

Received 20.12.18

Revised 15.04.19

Accepted 07.05.19

М.Г. Сур'янінов¹, Ю.А. Отрош², П.Г. Балдук¹, І.Ф. Дадашов³

¹Одеська державна академія будівництва та архітектури,

вул. Дідріхсона, 4, Одеса, 65029, Україна,

+380 50 333 3754, sng@ogasa.org.ua

²Національний університет цивільного захисту України.

вул. Чернишевська, 94, Харків, 61023, Україна,

+380 63 794 5621, yuriyotrosh@gmail.com

³Академія МНС Азербайджанської Республіки,

вул. Ельмана Гасимова, 8, пос. Говсани, Баку, AZ1089, Азербайджан,

+994 50 516 7695, llgardadashov.69@gmail.com

ЕКСПЕРИМЕНТАЛЬНІ ТА КОМП'ЮТЕРНІ ДОСЛІДЖЕННЯ ЗАЛІЗОБЕТОННИХ КОЛОН ЗА ВИСОКИХ ТЕМПЕРАТУРНИХ ВПЛИВІВ

Вступ. Незадовільний технічний стан багатьох будівель та споруд є наслідком їх старіння та потребує невідкладної оцінки технічного стану.

Проблематика. Оскільки аналітично складно описати напружено-деформований стан конструкцій, необхідно проводити експериментальні дослідження. Найбільш перспективним шляхом верифікації таких експериментальних досліджень є комп'ютерне моделювання конструкцій, зокрема й під час пожежі.

Мета. Експериментальні дослідження напружено-деформованого стану залізобетонної колони за високих температур та комп'ютерне моделювання цього процесу з подальшим його аналізом.

Матеріали й методи. Проведено експериментальні вогневі випробування залізобетонних колон з метою визначення проміжку часу від початку випробування до настання нормованого для колони граничного стану з вогнестійкості за ознакою втрати опорної здатності в умовах стандартного температурного режиму. Характеристики бетону колон після виготовлення визначено неруйнівними методами. З метою оцінки якості експерименту та достовірності отриманого розподілу температур виконано комп'ютерне моделювання обох колон у програмному комплексі ANSYS R.17.1.

Результати. Проведено порівняльний аналіз результатів експериментальних досліджень та даних комп'ютерного моделювання. Розподіл температурного поля по колоні є неоднозначним і залежить від розташування контрольних точок.

Висновки. Підтверджено, що методику проведених експериментальних досліджень і комп'ютерного моделювання з подальшим чисельним аналізом може бути рекомендовано для практичного застосування. Математична модель дає можливість оперативного прогнозування значень контрольованих параметрів будівельних конструкцій. Висновок про експлуатаційну придатність будівельних конструкцій з врахуванням можливої тенденції до погіршення їхнього технічного стану при силових та високотемпературних впливах має рекомендаційний характер.

Ключові слова: ANSYS, пожежа, комп'ютерне моделювання, залізобетонні колони, будівельні конструкції.